



YOUR BEST OPTION



REGO

Interconnect & Thermal solution

Fast Facts

REGO ELECTRONICS INC.

- Established : Oct . 2008
- Capital : USD 1.1 millions
- Quality Certification :
ISO9001-2015 & **ISO14001** Certificated
- Product : Interconnect & Thermal Solution



- New Office (Aug 2022) : 2248 m²
8F., No. 431, Baochang Rd., Xizhi Dist.,
New Taipei City 221036 , Taiwan



Core Values

Reliability - Not only reliable products & services, but devote ourselves in having a long-lasting relationship with our customers, suppliers and staffs.

Execution - We take every project seriously. We follow Plan-Do-Check-Action procedure to execute thoroughly.

Growth - We take every step stably and progress with a sustainable growth.

Orientation - We set our targets and work toward to our targets steadily. And, we complete our tasks collaboratively.

Vision



“We dedicate ourselves to being one of the most important suppliers for key components to interconnect & thermal products needed in ***Hi-tech industry, Networking*** and ***Industrial computing*** globally.”

Sales & Marketing



Sales Territory

- ◎ Taiwan & China : 65%
- ◎ Overseas : 35%

Market Focus

- ◎ Industrial Applications
- ◎ Storage & Server
- ◎ Surveillance
- ◎ Network & Comm.

Business Model

- ◎ Focus on high-tech niche market
- ◎ Discover new business opportunities ahead
- ◎ Provide irreplaceable services and solutions

Growth Plan – Our Pace

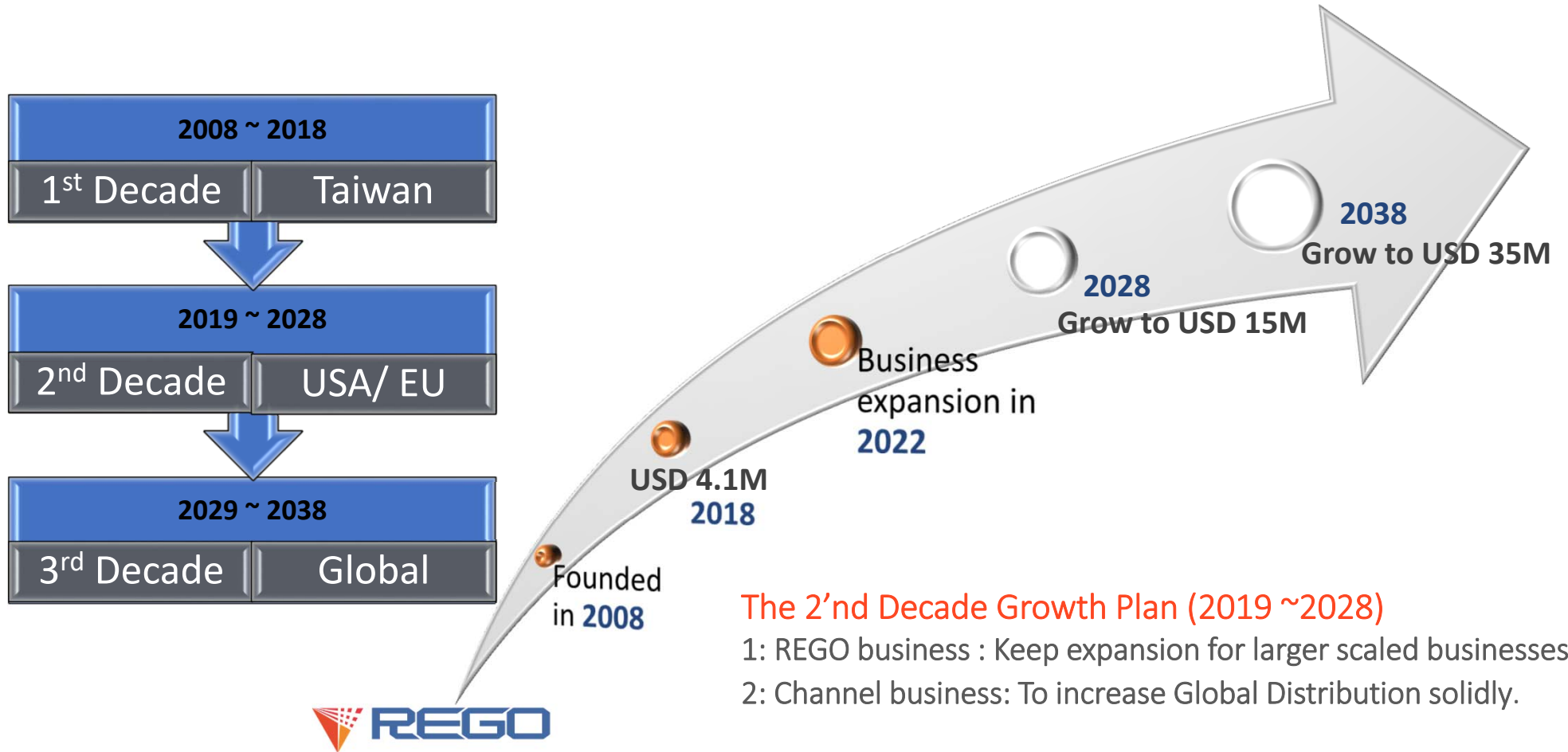

The 2nd Decade Growth Plan (2019 ~2028)

- 1: REGO business : Keep expansion for larger scaled businesses.
- 2: Channel business: To increase Global Distribution solidly.

Revenue Growth Plan

2028 Target : 15 millions

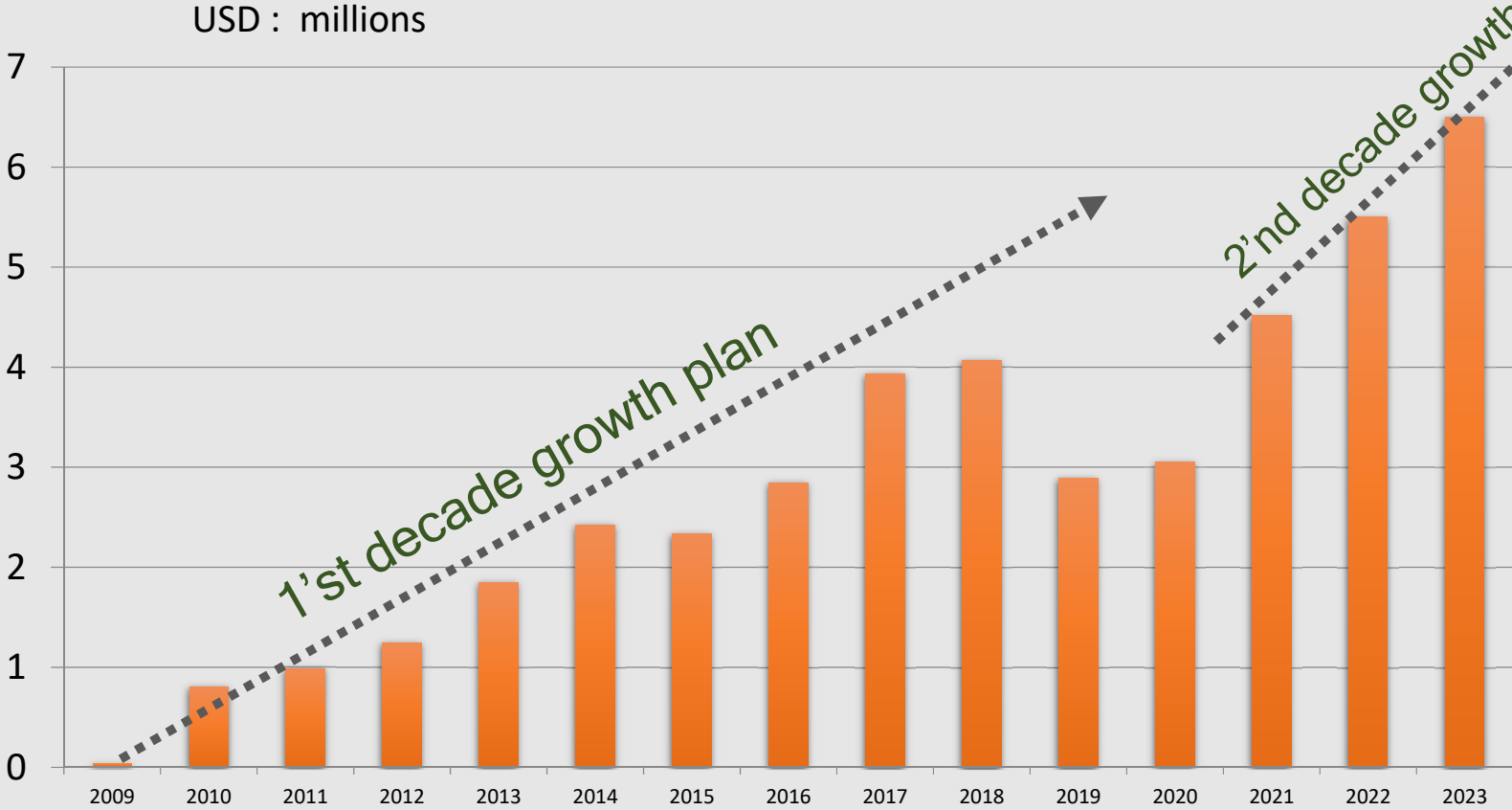

2028 Target

Present : Y2023

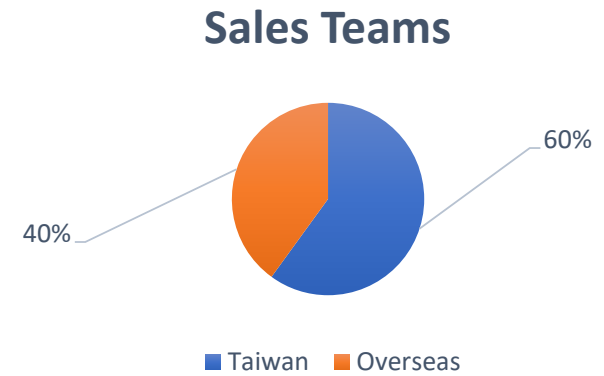
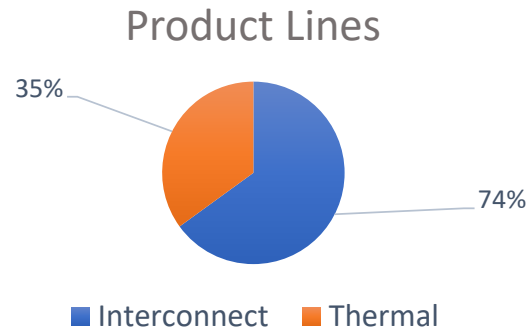

Target : Y2028

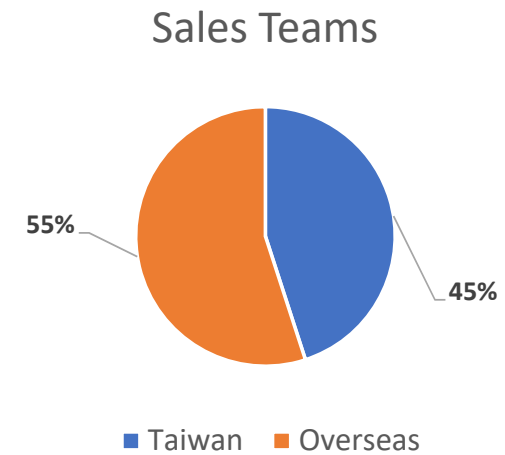
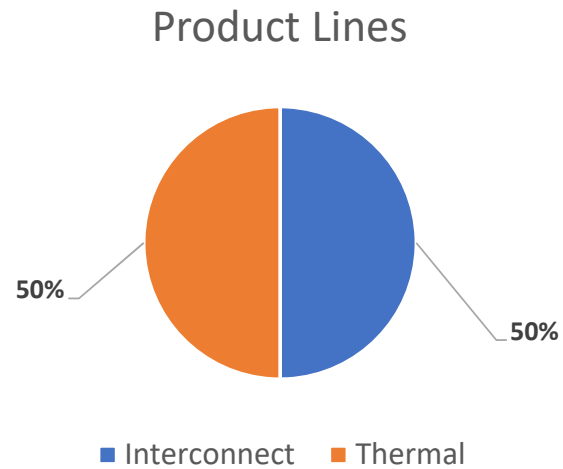

Possibility

Flexibility

Opportunity

REGO

INTERCONNECT

Thermal solutions

Networking Communication

Industrial Computing

Portable Device

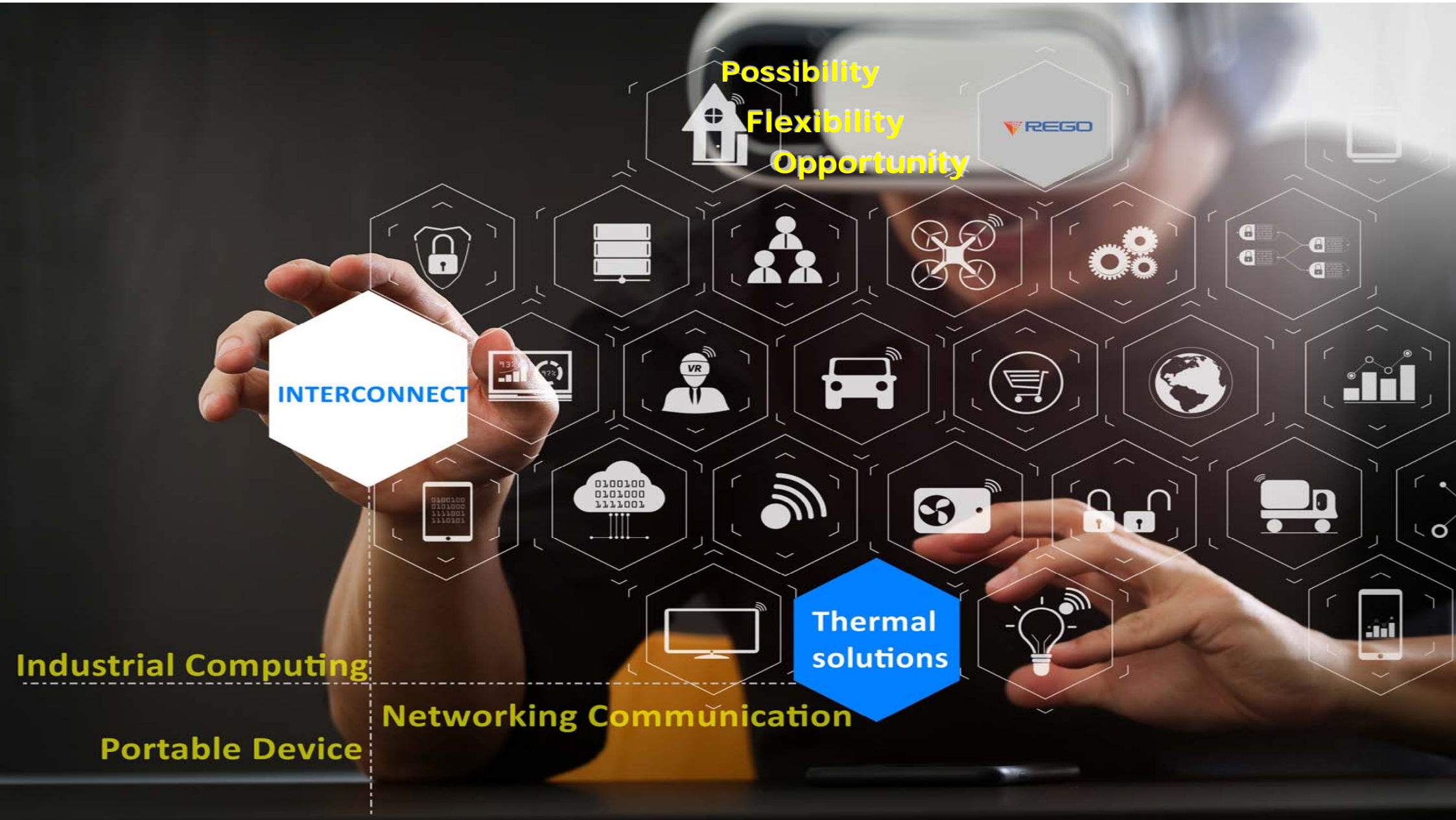

Revenue (2023 by markets)

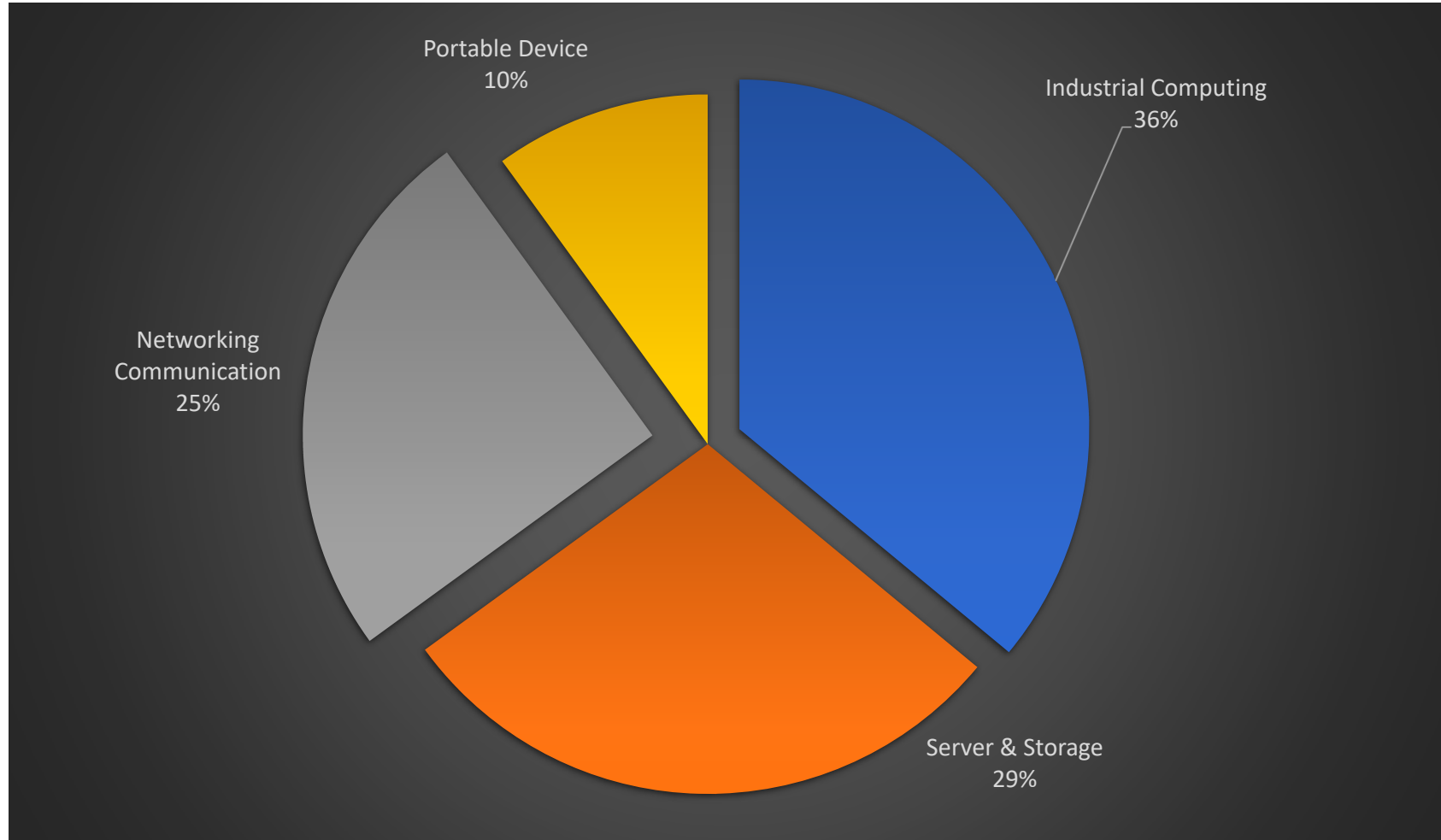

Revenue (2023 by Products)

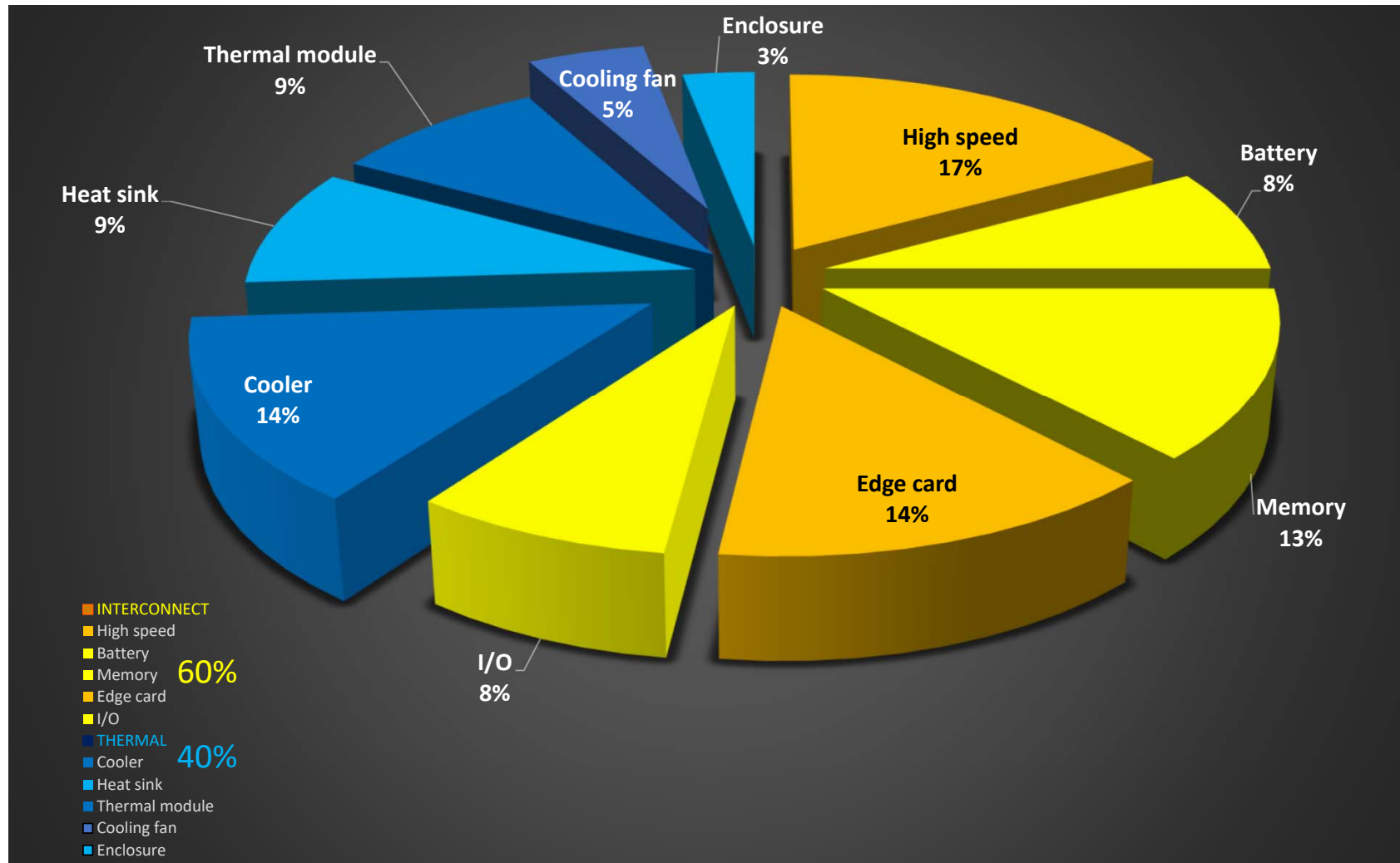

PROVIDE WHAT YOU NEED

-- Not just what you want only --

REGO **designs and provides** total thermal solution
to help our customers succeed!

what you expect, what we do
ONE STOP SOLUTION

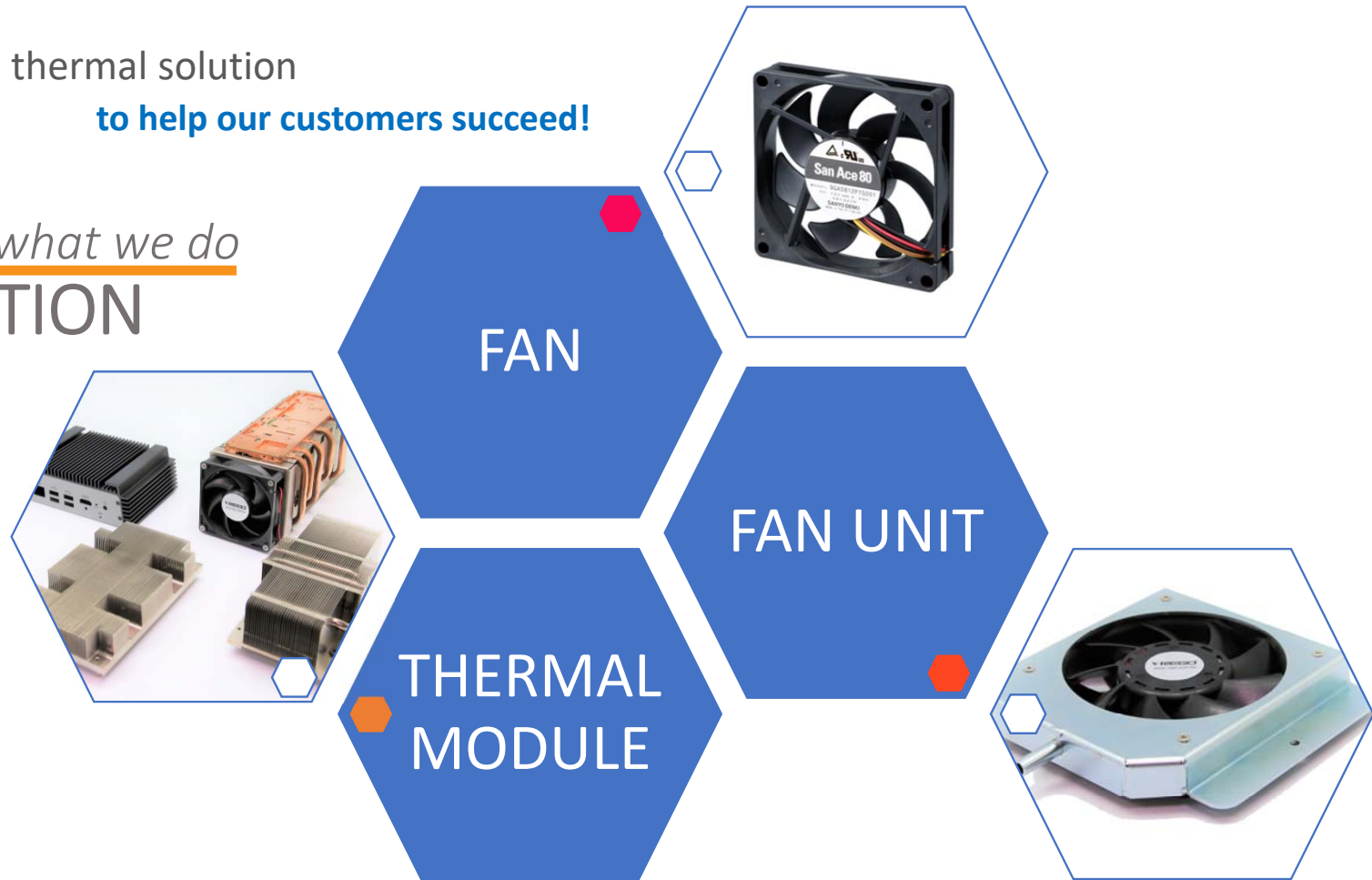

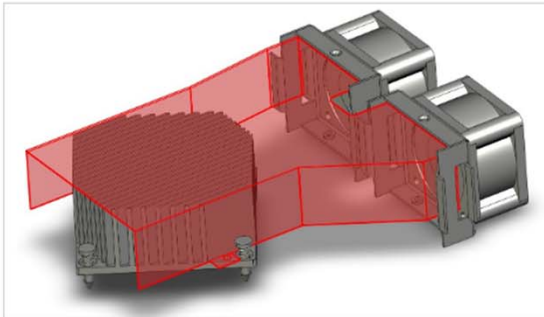

| Server application, 55W [Belgium]

To try to resolve the heat issues from the chassis of server, including the QSFP and SFP connections, by heat sink & 4 fans.

[Analysis](#) 

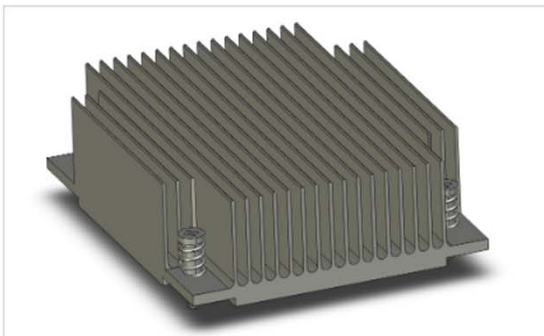

| Server application, AMD EYPC3000, 100W [USA]

To resolve the heat issue by optimizing the thermal concept to better fit the thermal performance expected by customer, including the buffer reserved for overclocking operations if any.

[Analysis](#) 

Technical Service

◆ ACCURATE THERMAL DESIGN & SIMULATION

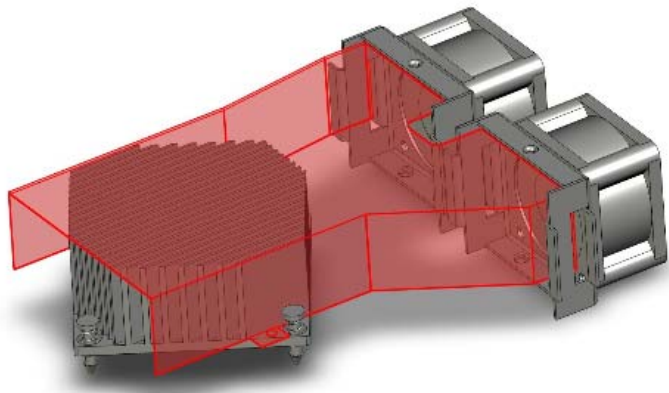

◆ RIGOROUS TEST & VERIFICATION

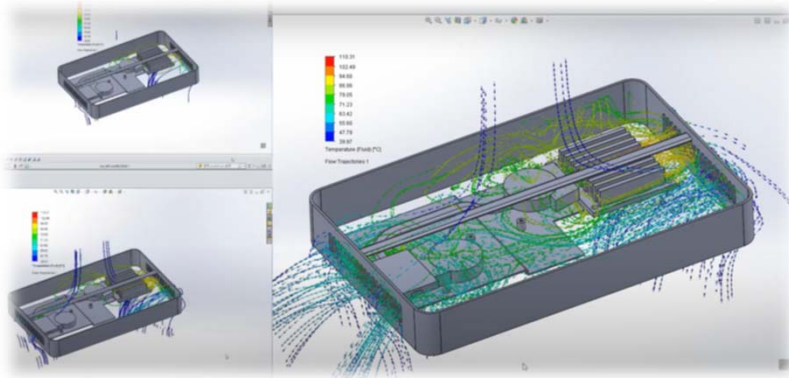

Technical Service

◆ QUICK MAKING SAMPLE



CNC MACHINING CENTER

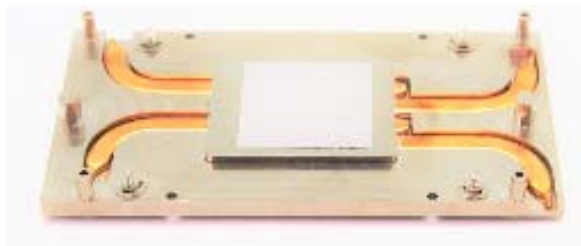

THERMAL MODULE

◆ RELIABLE PERFORMANCE TEST & QUALITY ASSURANCE

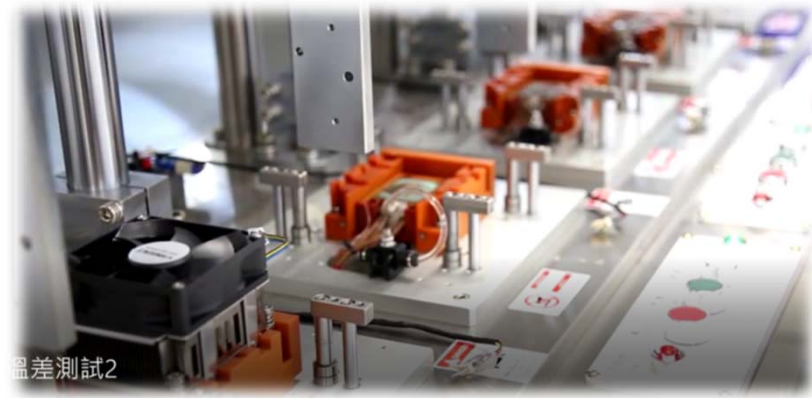
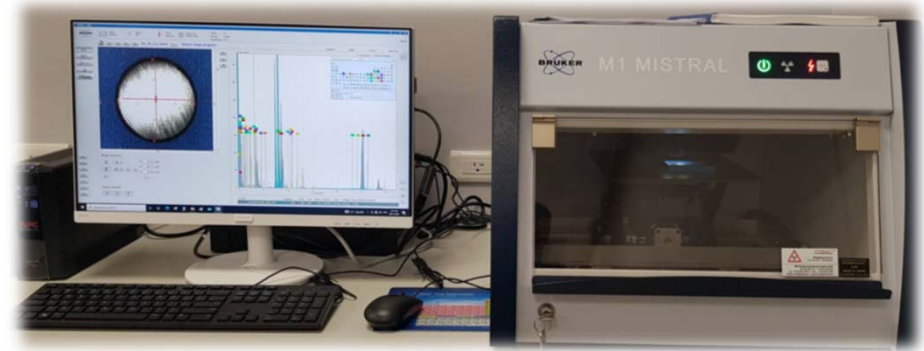

More details sharing
 would get closer to the best
 cost-effective solution easily!

Project Registration Form

| | |
|--|---------------------------------------|
| 1. Customer 【客戶】 / website | |
| 1-1. End User 【最終客戶】 / website : | Mandatory |
| 1-2. EMS/ CM 【代工廠】 : | |
| 2. Part Number 【產品料號】 or Product Specification 【產品規格】 : | |
| | Mandatory |
| 3. Substitute 【找替代料】 or For New Project 【新開發案件】 : | |
| | Mandatory |
| 4. Project Information 【案件資訊】 | |
| 4-1. Application 【產品應用】 : | Mandatory |
| 4-2. Project Name 【專案名稱】 / Model No. : | |
| 4-3. EAU(Estimate Annual Usage) 【年用量】 : | Mandatory |
| 4-4. Sample Run Schedule 【樣品排程】 : | |
| 4-5. MP/ Start of Production Schedule 【量產排程】 : | Mandatory |
| 4-6. Life Cycle 【產品生命週期】 : | |
| 5. Competitor 【競爭對手】 : | |
| | |
| Remark: | |
| | |
| Project Registration Number (to be given after registration) | to be issued & filled up by REGO team |

NOTE:

1. All information above disclosed by applicants would be used for completion of project registration at REGO. As soon as getting successful registration from REGO (to be given the project registration number), Registers could get the project protection made by REGO to ensure the effort of spec-in they've made.

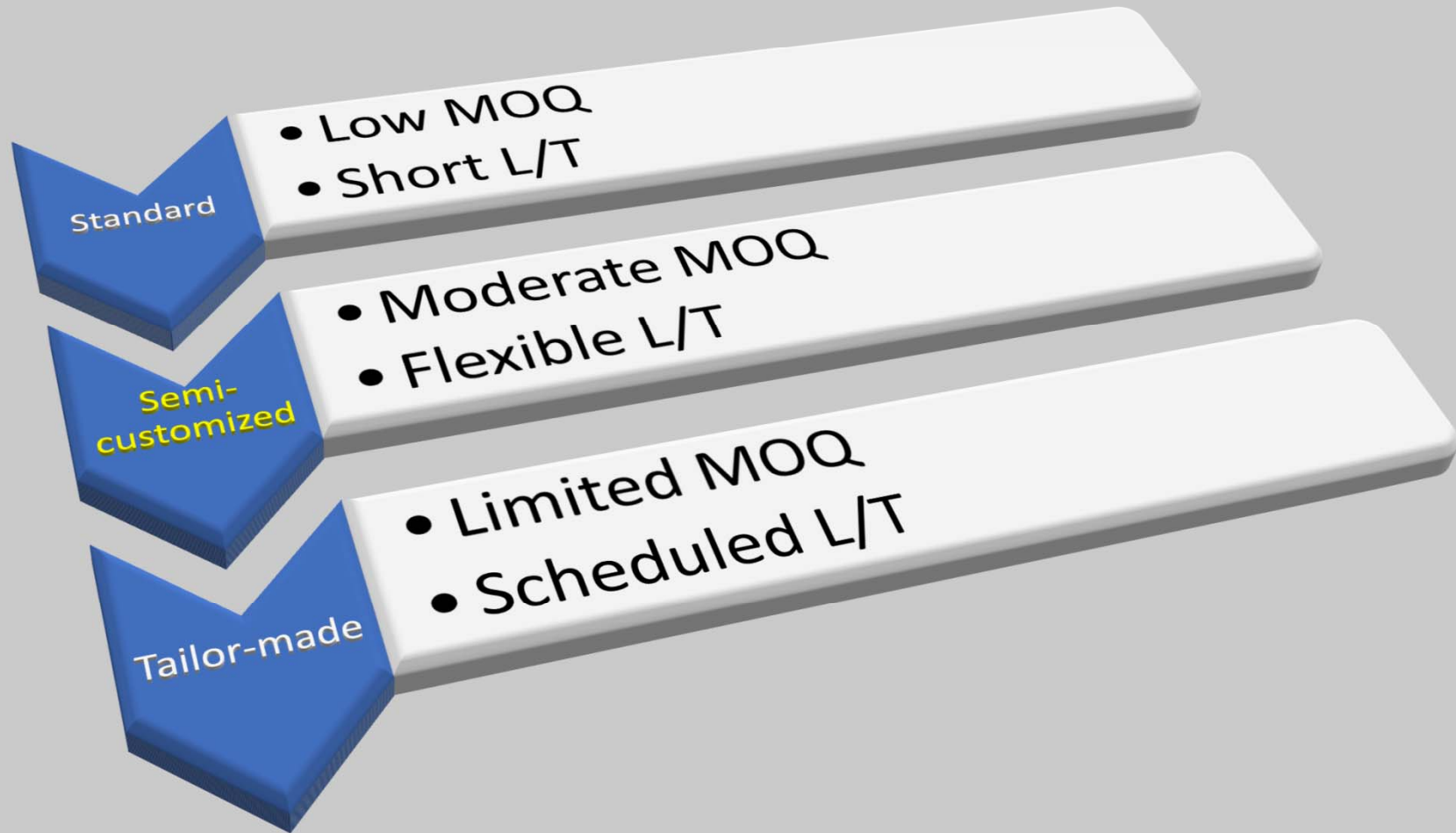

MORE THAN CONNECTION, BUT COMPREHENSION

-- One Stop Solutions for Cost Saving --

Quick Search Helper - Wide range for easy selection!



A great diversity of interconnect & thermal solutions

Home **INTERCONNECT** THERMAL NEWS CONTACT US ABOUT REGO Search... SEARCH

- ▶ Power Connectors
- ▶ Input/Output Connectors
- ▶ FPC/FFC Connectors
- ▶ SATA/SAS Connectors
- ▶ Memory Card Sockets
- ▶ Edge Card Connectors
- ▶ Battery Connectors
- ▶ Board to Board Connectors
- ▶ SMD Standoff Nuts
- ▶ Backplane Connectors
- ▶ Cable Assemblies
- ▶ Bandolier Pins
- ▶ USB Combo Plug
- ▶ SSD Case & Connector Kits



BACK

High Speed Cable Assemblies

Rego is capable of unlimited design and verification of the Mechanical and PCB design, Electrical design, Signal Integrity Analysis, EMC and Heat Sink knowledge. Our production is 100% signal integrity tested with ATE machines and all test data are saved and backed up. Rego offers the high speed cable assemblies for SFP, SFP+, QSFP, mSAS, mSAS HD, etc. Please contact us for further information directly.

High Speed Cable Assemblies Series



Mini SAS HD Cable Assemblies (SFF-8643 & SFF-8644)
Product Series - Mini SAS HD Internal and External Cable Assemblies Features & Benefits - Rego's Mini SAS HD...



SFP+, QSFP, QSFP 100Gbps & QSFP-DD Cable Assemblies
Features & Benefits - Standardized cables from 24 to 32AWG - Hot plug swappable / Optimized NEXT & Return L...



Micro Coaxial Cable Assemblies
Product Series - Pitch 0.4mm & 0.5mm micro coaxial cable assemblies Features & Benefits - A set includes a ...



RF Coaxial Cable Assemblies
Product Series - Micro Coax, BNC, SMA, SMB, SMC, MCX, and MMCX connectors assembled with various sizes of coaxial cable...

FEATURED

RJ45 w / transformer
RF
Power
High Spd BTB

SURVEILLANCE



AUTOMATION



GAMING

MEDICAL



VALUE-ADDED

HDMI / DP 2in1
CFexpress

POPULAR

M.2 Set
Spring battery

CONNECT YOURs TO MARKET
All various connections you'll need in different applications or designs, it's welcome to reach us to get quick proposal from our sales team or global partners around you by sharing your thoughts or demands.



Industrial computing



Networking Communication & Server



Nowadays, it's getting faster and faster for data transmission and exchanging by considering update to date networking technology. As one of the leading solution providers in Taiwan, our teams are always prepared to proactively assist each of our customers to meet the harsh conditions in the state of art designs.

- ④ MINI SAS HD Connector for SFF-8644 & SFF-8643
- ④ U.2 Connector (SFF-8639)
- ④ Backplane Connectors: DIN41612 、 Future Bus 、 Hard Metric
- ④ Backplane POWER Connectors
- ④ RJ45 Connector with 1G 、 10G Base-T 、 with USB3.0
- ④ High Speed Cable Assemblies Series
- ④ Mini SAS HD Cable Assemblies for SFF-8643 & SFF-8644



Make things smaller

Portable Product (Mobile Computer)

- Micro USB - USB3.1 Type C
- Spring Type & POGO PIN Type for Battery Connector
- Micro SD Card Sockets Series
- Micro SIM & Nano SIM Card Sockets Series
- FPC Connector



Main reasons why customers stay with REGO

-- SINCE STARTED THEIR FIRST PROJECT WITH US --

Mostly Preferred

- ✓ **Long-lasting relationship** - Rego provides reliable products and services. We maintain a long-lasting relationship with our customers, principals, suppliers and staffs.
- ✓ **One-Stop-shopping** - Rego offers One-Stop-shopping for a full package of interconnect products & thermal solutions.
- ✓ **Technical Support** - Rego has a strong Technical Support Team helps customers starting from the design phase all the way to manufacturing. We provide not only the standard products but also customized services.
- ✓ **On-time delivery** - As a responsible distributor, REGO assists in purchasing and inventory planning, helping principal's production and on-time delivery to customers.
- ✓ **Quick & Proactive** - Our team is committed to provide quick response and proactive support to our principals and customers.



Sales Network

Ineltro
Europe Sales – Austria/
Germany
(Distributor)

Mouser
Global E-Store
(Distributor)

amec
Europe Sales – Germany
(Sales rep)

Komtek
Russia Sales - SPB
(Distributor)

Rapidtek-SHH
East China Sales
(Distributor)

Pretech
Asia Sales – Singapore/
Malaysia
(Distributor)

Kaztech
Asia Sales - Japan
(Sale rep)



Nitin Saxena
Asia Sales - India
(Sales rep)

Nippon-Mik
Asia Sales - Japan
(Sale rep)

Our Customers

| EMBEDDED | INDUSTRIAL | NETWORKING |
|---|--|---|
|   |  |  |
|   |  |   |
|  |   |   |
|  +  |   <small>Quality connecting the next</small> |   |
|  |   <small>imagine. change.</small> |   |
| |  <small>Building a future we can all trust</small> |  |



We look forward to working with your
company in the future!!

 **REGO[®] ELECTRONICS INC.**
A great diversity of interconnect & thermal solutions